

GEM-FLOW™ | G500-PR

Pressure Reducing 1-1/2" - 4"

Description

G500-PR model pressure reducing control valve is the hydraulic control valve which reduces high upstream pressure value to desired lower pressure value by means of built-in pressure reducing pilot valve. Pressure reducing control valve controls downstream pressure value continuously and maintains it constant without being affected from flow rate and upstream pressure values. When no flow exists in the system, it closes itself automatically. When valve upstream pressure value is lower than set point, it is opened fully by itself. Valve may be used in vertical or horizontal positions in the system.



Applications

- Use G500-PR for irrigation, water distribution and filtration systems
- Smart designed G500-PR provides high corrosion resistance

Standards

- G500-PR: 3 Way plastic pressure reducing pilot, polyethylene plastic tubing system and nylon fittings
- G500-PRM: 3 Way plastic pressure reducing pilot, polyethylene plastic tubing system, nylon fittings and 3 Way selector
- Standard pressure adjustment from factory: 2.5 bar

How to Order

G500	TYPE	PORT	PRESSURE RANGE
without Manual Selector	PR	1-1/2" BSPT 70	0.5-5 bar Y
with Manual Selector	PRM	1-1/2" NPT 71	1-10 bar G
		2" BSPT 80	
		2" NPT 81	
		2-1/2" BSPT 85	
		2-1/2" NPT 86	
		3" BSPT 90	
		3" NPT 91	
		4" BSPT 100	
		4" NPT 101	
		4" Flange 100F	

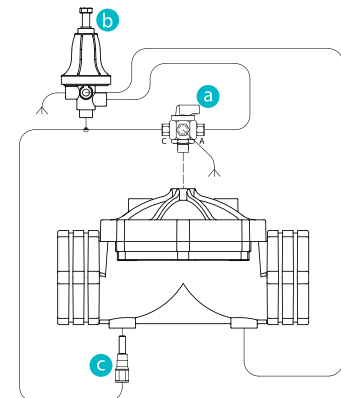

- a 3W selector valve
- b Plastic Pilot
- c In-line finger filter

Example: G500-PR-80G

GEM-FLOW™ G500 pressure reducing without manual selector, 2" BSPT, 1-10 bar

* To order valves manufactured according to your specific requirements, please contact our technical sales department