

GEM-FLOW™ | G500-PS

Pressure Sustaining Control Valve 1-1/2" - 4"

Description

G500-PS model pressure sustaining hydraulic control valve maintains valve upstream pressure value constant. Valve is opened when line pressure reaches the preset pressure level. It ensures that pump motor within pumping systems will start without load. It also prevents positive pressure waves caused by pump during start-up. The valve controls upstream pressure value continuously and keeps it at a constant value without being affected from changes in flow rate. When no flow exists, it closes tightly by itself.

* For technical information, refer to G75-A and G75-A3P solenoid valves



Applications

- Use G500-PS for maintaining a constant upstream pressure or to avoid unwanted high pressure

Standards

- G500-PS: 3 Way plastic pressure sustaining pilot, polyethylene plastic tubing system and nylon fittings
- G500-PSM: 3 Way plastic pressure sustaining pilot, polyethylene plastic tubing system, nylon fittings and 3 Way selector
- Standard pressure adjustment from factory: 2.5 bar

How to Order

G500	TYPE	PORT	VOLTAGE	WIRES	PRESSURE RANGE
without Manual Selector	PS	1-1/2" BSPT 70	No solenoid (hydraulic)	0	0.5-5 bar Y
with Manual Selector	PSM	1-1/2" NPT 71	24V AC	1	1-10 bar G
		2" BSPT 80	24V AC w/out Diode	1R	
		2" NPT 81	12V AC	3	
		2-1/2" BSPT 85	12V DC	4	
		2-1/2" NPT 86	24V DC	5	
		3" BSPT 90	23Ω	6	
		3" NPT 91	4Ω	B	
		4" BSPT 100	9Ω	C	
		4" NPT 101	12Ω	D	
		4" Flange 100F	1Ω ⁽¹⁾	PA	
			4Ω ⁽¹⁾	PB	
			9Ω ⁽¹⁾	PC	

Example: G500-PSM-801G

GEM-FLOW™ G500 pressure sustaining with manual selector, 2" BSPT, 24V AC, two wires, 1-10 bar

- (1) For G75-A3P Latch
(2) For Latch only

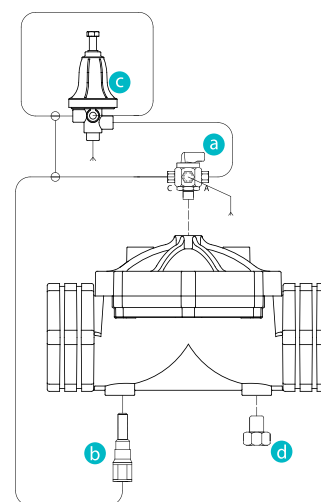

- a 3W selector valve
- b In-line finger filter
- c Plastic Pilot
- d Plug

* To order valves manufactured according to your specific requirements, please contact our technical sales department